

# Turmdrehkran

Tower Crane / Grue à tour / Gru a torre / Grúa torre  
Guindaste de torre / Башенный поворотный кран

## 280 EC-H 12 Litronic®

▶ 280 EC-H 12 Litronic®

280 EC-H 16 Litronic®

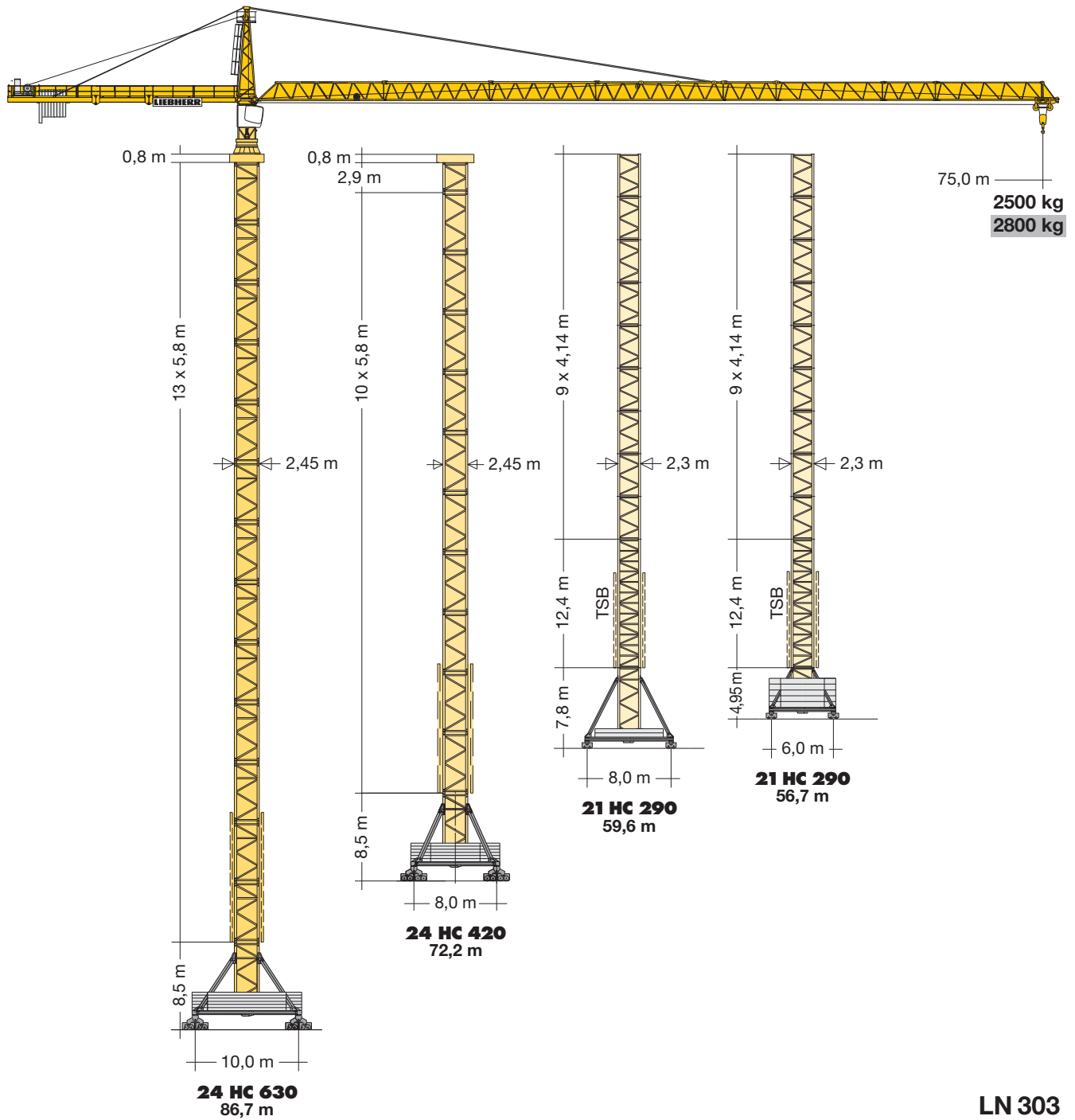

LN 303

# LIEBHERR

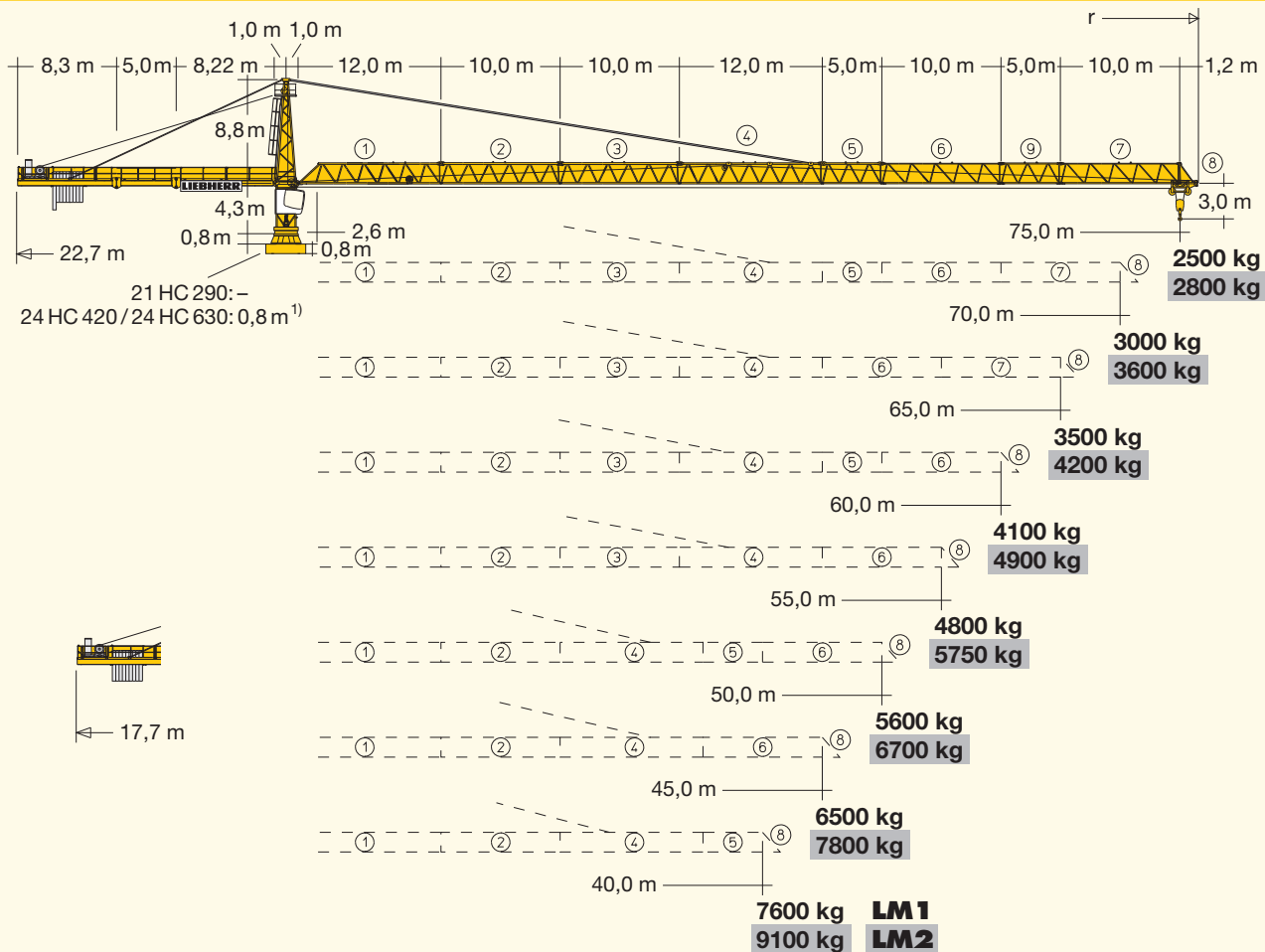

1) **Übergangsrahmen 21 HC 290 – 24 HC 630 TF.** / Transition frame 21 HC 290 – 24 HC 630 TF. / Cadre de raccordement 21 HC 290 – 24 HC 630 TF. / Adattatore torre 21 HC 290 – 24 HC 630 TF. / Marco de transición 21 HC 290 – 24 HC 630 TF. / Quadro de transição 21 HC 290 – 24 HC 630 TF. / Переходная рама 21 HC 290 – 24 HC 630 TF.

## Hubhöhe

Hoisting height / Hauteur sous crochet / Altezza di sollevamento  
 Altura bajo gancho / Altura de montagem / Высота подъема

LN 303	21 HC 290			24 HC 630	
14	-	-	-	84,4 <sup>2)</sup>	-
13	-	-	-	78,7	86,7 <sup>2)</sup>
12	-	-	-	72,9	81,0
11	-	-	-	67,1	75,2
10	-	-	-	61,3	69,4
9	52,0 <sup>2) 3)</sup>	56,7 <sup>2) 3)</sup>	59,6 <sup>2) 3)</sup>	55,5	63,6
8	47,9 <sup>2)</sup>	52,6 <sup>2)</sup>	55,5 <sup>2)</sup>	49,7	57,8
7	43,7	48,4 <sup>2)</sup>	51,3	43,9	52,0
6	39,6	44,3	47,2	38,1	46,2
5	35,4	40,1	43,0	32,3	40,4
4	31,3	36,0	38,9	26,5	34,6
3	27,2	31,9	34,8	20,7	28,8
2	23,0	27,7	30,6	14,9	23,0
1	18,9	23,6	26,5	9,1	17,2
0	m 14,7	19,4	22,3	m 3,3	11,4

--	--	--	--	--

2) **LM 2 Nicht möglich.** / Not possible. / Pas possible. / Non possibile. / No posible. / Nao é possível. / Не возможно.

**Weitere Hubhöhen, Auslegerlängen sowie Klettern im Gebäude auf Anfrage.** / Further hoist heights and jib lengths as well as climbing inside the building on request. / Autres hauteurs sous crochet et longueurs de flèche ainsi que hissage dans le bâtiment sur demande. / Ulteriori altezze gancho, lunghezze braccio così come telescopaggio all'interno dell'edificio: su richiesta. / Para alturas bajo gancho superiores, otros alcances y trepado en el interior del edificio, consultar. / Outras alturas de elevação, comprimentos de lança e subida no edifício: sob consulta. / Другие высоты подъема, длины стрелы и самоподъем в здании – по запросу.

		<b>280 EC-H 12</b>														
m	r	m/kg	m/kg													
			22,0	25,0	28,0	31,0	34,0	37,0	40,0	45,0	50,0	55,0	60,0	65,0	70,0	75,0
<b>75,0</b>	<b>(r = 76,6)</b>	2,6-21,2 12000	11500	9950	8750	7770	6970	6310	5740	4970	4350	3840	3420	3070	2760	<b>2500</b>
<b>70,0</b>	<b>(r = 71,6)</b>	2,6-22,4 12000	12000	10620	9340	8310	7470	6760	6160	5340	4680	4150	3700	3320	<b>3000</b>	
<b>65,0</b>	<b>(r = 66,6)</b>	2,6-23,3 12000	12000	11090	9760	8690	7810	7070	6450	5590	4910	4360	3890	<b>3500</b>		
<b>60,0</b>	<b>(r = 61,6)</b>	2,6-24,3 12000	12000	11600	10210	9090	8180	7410	6760	5870	5160	4580	<b>4100</b>			
<b>55,0</b>	<b>(r = 56,6)</b>	2,6-25,2 12000	12000	12000	10640	9480	8530	7740	7060	6140	5400	<b>4800</b>				
<b>50,0</b>	<b>(r = 51,6)</b>	2,6-25,9 12000	12000	12000	11000	9800	8820	8000	7310	6360	<b>5600</b>					
<b>45,0</b>	<b>(r = 46,6)</b>	2,6-26,4 12000	12000	12000	11230	10010	9010	8180	7470	<b>6500</b>						
<b>40,0</b>	<b>(r = 41,6)</b>	2,6-26,8 12000	12000	12000	11410	10180	9170	8320	<b>7600</b>							

**LM 1**

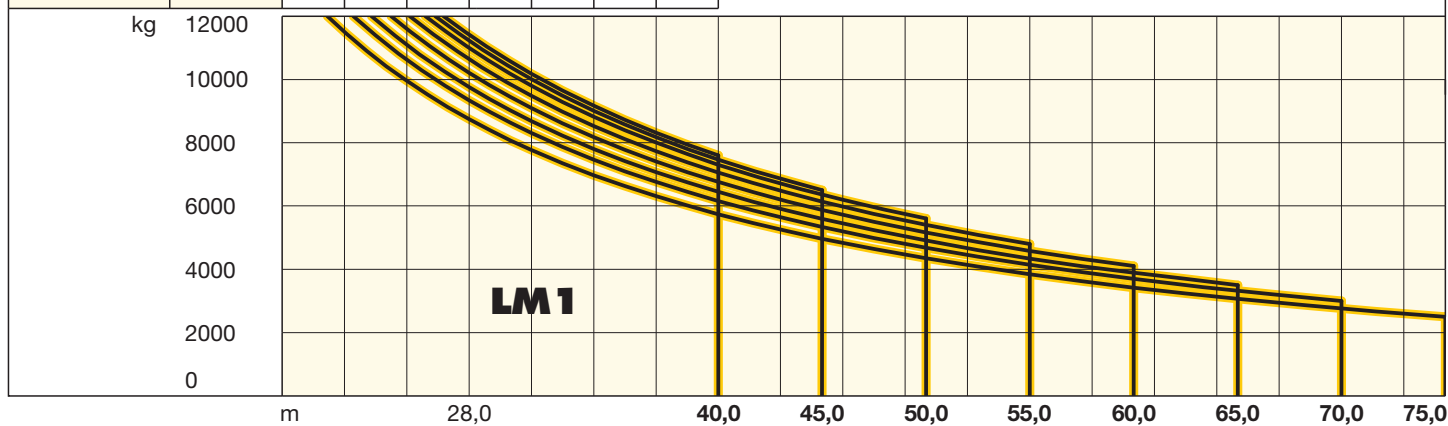

5,8 m + 2,9 m		LN 303	<b>24 HC 420</b>		
11			67,0 <sup>2)</sup>		68,8 <sup>2)</sup>
10 + 1			64,1 <sup>2)</sup>		65,9 <sup>2)</sup>
10			61,2		63,0
9 + 1			58,3		60,1
9			55,4		57,2
8 + 1			52,5		54,3
8			49,6		51,4
7 + 1			46,7		48,5
7			43,8		45,6
6 + 1			40,9		42,7
6			38,0		39,8
5 + 1			35,1		36,9
5			32,2		34,0
4 + 1			29,3		31,1
4			26,4		28,2
3 + 1			23,5		25,3
3			20,6		22,4
2 + 1			17,7		19,5
2			14,8		16,6
1 + 1			11,9		13,7
1			9,0		10,8
0 + 1			6,1		7,9
0			3,2		5,0

m	

# Ausladung und Tragfähigkeit

Radius and capacity / Portée et charge / Sbraccio e portata  
Alcances y cargas / Alcance e capacidade de carga / Вылет и грузоподъемность

		280 EC-H 12 Litronic®														
m	r	m/kg	m/kg													75,0
			22,0	25,0	28,0	31,0	34,0	37,0	40,0	45,0	50,0	55,0	60,0	65,0	70,0	
75,0	(r = 76,6)	2,6-22,9 12000	12000	10860	9560	8500	7640	6920	6310	5470	4800	4250	3800	3410	3090	2800
70,0	(r = 71,6)	2,6-25,6 12000	12000	12000	10860	9680	8710	7900	7210	6270	5520	4910	4400	3970	3600	
65,0	(r = 66,6)	2,6-26,7 12000	12000	12000	11400	10160	9150	8310	7590	6610	5820	5180	4650	4200		
60,0	(r = 61,6)	2,6-27,9 12000	12000	12000	11940	10650	9600	8710	7970	6940	6120	5460	4900			
55,0	(r = 56,6)	2,6-29,1 12000	12000	12000	12000	11180	10070	9150	8370	7300	6450	5750				
50,0	(r = 51,6)	2,6-30,0 12000	12000	12000	12000	11590	10450	9500	8690	7580	6700					
45,0	(r = 46,6)	2,6-30,8 12000	12000	12000	12000	11900	10740	9760	8930	7800						
40,0	(r = 41,6)	2,6-31,3 12000	12000	12000	12000	12000	10930	9940	9100							

LM1 + LM2

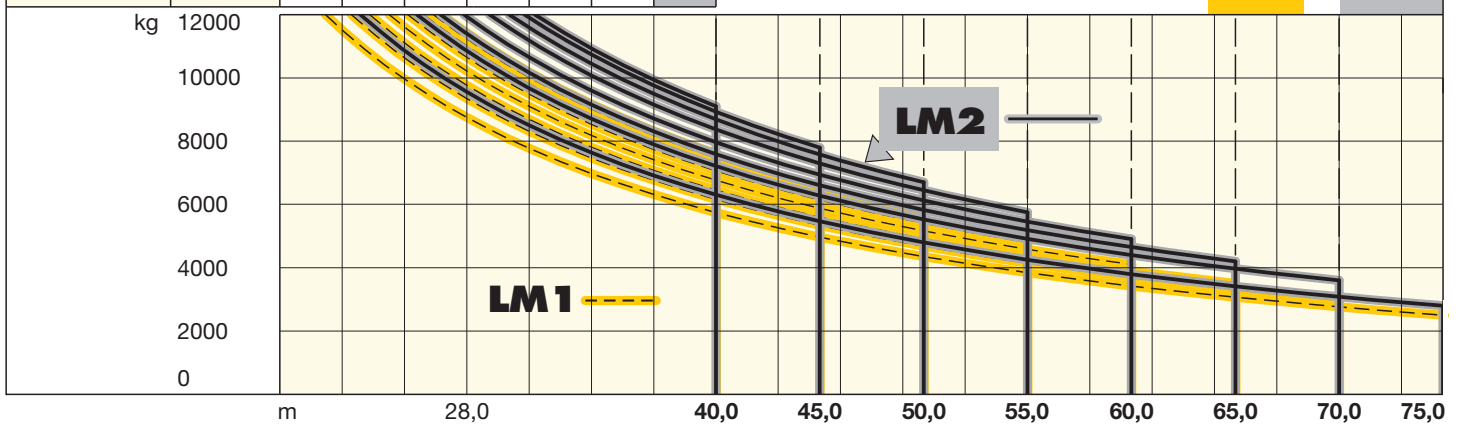

## Antriebe Litronic®

Driving units / Mécanismes d'entraînement / Meccanismi / Mecanismos / Mecanismos / Приводы

↔ **stufenlos** / stepless / régl. continu  
regl. progressiva / sin escalones / sem degraus  
бесступенчатый kg m/min

45 kW FU  
WIW 260 MZ 417

**5 Lagen**  
Layers  
Couches  
Avvolgimenti  
Camadas  
Capas  
Слоёв

189,0 m

max. 325,0 m<sup>4)</sup>

1

12000 0 ↔ 20  
650 0 ↔ 116

↔ **stufenlos** / stepless / régl. continu  
regl. progressiva / sin escalones / sem degraus  
бесступенчатый kg m/min

65 kW FU  
WIW 280 MZ 415

**5 Lagen**  
Layers  
Couches  
Avvolgimenti  
Camadas  
Capas  
Слоёв

189,0 m

max. 325,0 m<sup>4)</sup>

1

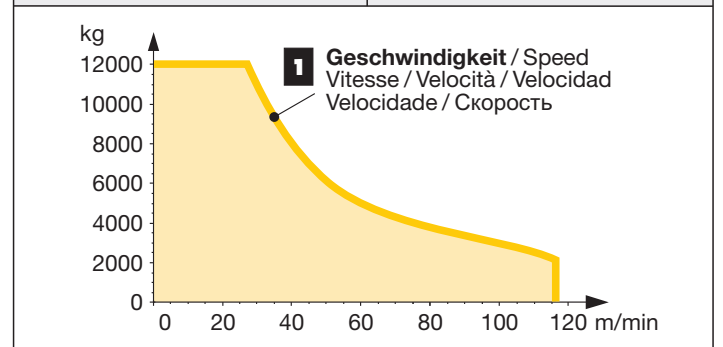
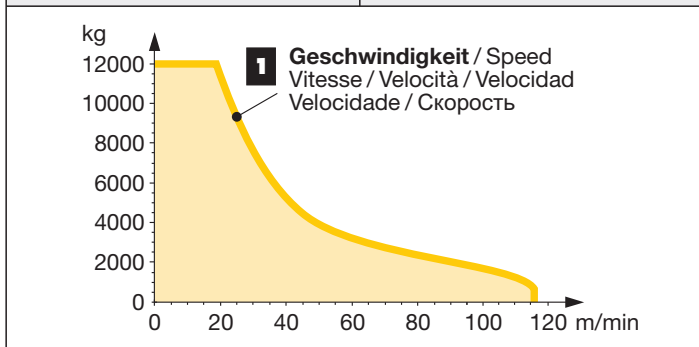

12000 0 ↔ 28  
2200 0 ↔ 116

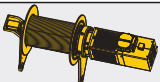
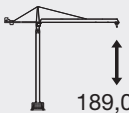

<sup>4)</sup> Weitere Hublastdaten: siehe Betriebsanleitung. / Further hoist load data: see instruction manual. / Autres données de la charge de levage: voir manuel d'instruction. / Altri dati sui carichi sollevati: consultare il manuale d'istruzione. / Alturas bajo grancho superiores según manual. Outras tabelas de carga: consultar manual de instruções. / Другие данные по весу поднимаемых грузов: см. инструкцию по эксплуатации.

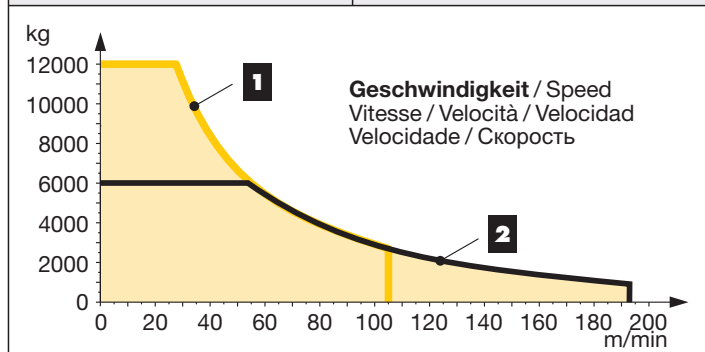
	↔ <b>stufenlos</b> / stepless / régl. continu regl. progressiva / sin escalones / sem degraus бесступенчатый kg m/min								
65 kW FU [SD.shift] WIW 280 WZ 402 <b>5 Lagen</b> Layers Couches Avvolgimenti Camadas Capas Слоёв   189,0 m  max. 325,0 m <sup>4)</sup>	<table border="0"> <tr> <td><b>1</b></td> <td>12000 0 ↔ 27</td> </tr> <tr> <td></td> <td>2700 0 ↔ 105</td> </tr> <tr> <td><b>2</b></td> <td>6000 0 ↔ 53</td> </tr> <tr> <td></td> <td>900 0 ↔ 192</td> </tr> </table>	<b>1</b>	12000 0 ↔ 27		2700 0 ↔ 105	<b>2</b>	6000 0 ↔ 53		900 0 ↔ 192
<b>1</b>	12000 0 ↔ 27								
	2700 0 ↔ 105								
<b>2</b>	6000 0 ↔ 53								
	900 0 ↔ 192								

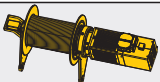

	↔ <b>stufenlos</b> / stepless / régl. continu regl. progressiva / sin escalones / sem degraus бесступенчатый kg m/min								
110 kW FU [SD.shift] WIW 300 WZ 401 <b>5 Lagen</b> Layers Couches Avvolgimenti Camadas Capas Слоёв   189,0 m  max. 325,0 m <sup>4)</sup>	<table border="0"> <tr> <td><b>1</b></td> <td>12000 0 ↔ 49</td> </tr> <tr> <td></td> <td>3100 0 ↔ 156</td> </tr> <tr> <td><b>2</b></td> <td>5500 0 ↔ 97</td> </tr> <tr> <td></td> <td>1400 0 ↔ 266</td> </tr> </table>	<b>1</b>	12000 0 ↔ 49		3100 0 ↔ 156	<b>2</b>	5500 0 ↔ 97		1400 0 ↔ 266
<b>1</b>	12000 0 ↔ 49								
	3100 0 ↔ 156								
<b>2</b>	5500 0 ↔ 97								
	1400 0 ↔ 266								

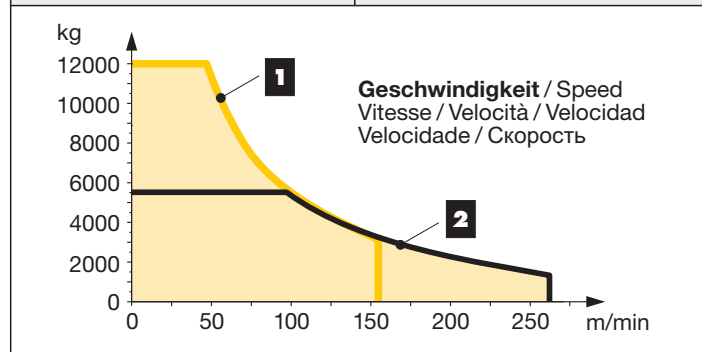



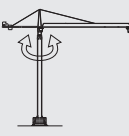
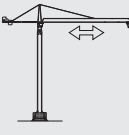
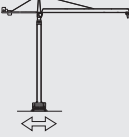







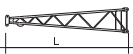









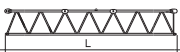







**LM 2** Abweichende Geschwindigkeiten und Betriebsbedingungen. / Variant speeds and service conditions. / Vitesses et conditions de fonctionnement différentes. / Differenti velocità e condizioni di funzionamento. / Otras velocidades y características de funcionamiento. Outras velocidades e características de funcionamento. / Нестандартные скорости и условия эксплуатации.

	U/min 0 ↔ 0,7 sl./min tr./min	2 x 7,5 kW FU
	0 ↔ 120,0 m/min	7,5 kW FU
	25,0 m/min	4 x 7,5 kW 24 HC 420 / 24 HC 630 2 x 7,5 kW 21 HC 290

 <b>kVA</b>	45 kW FU	65 kW FU	110 kW FU
	64,0	86,0	122,0















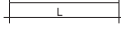

**Litronic® : kVA** reduzierbar bei zu geringer Netz-Anschlussleistung, siehe BAL. / kVA can be reduced in case of too little power of the mains, see instruction manual. / kVA peut être réduit en cas de trop faible puissance du réseau, voir manuel d'instruction. / kVA riducibili in caso di potenza di rete ridotta (si veda manuale uso e manutenzione) / kVA variable para potencia de red demasiado pequena, ver Manual de instrucciones. / kVA reduzível no caso de capacidade da rede elétrica muito baixa, ver manual de instruções. / Количество кВА может быть сокращено до минимальной общей потребляемой мощности, см. инструкцию по эксплуатации.

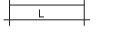
<b>Kranoberteil</b>		Upper part of crane / Partie supérieure de grue / Parte superiore della gru Parte superior grúa / Parte superior do guindaste / Верхняя часть крана	L (m)	B (m)	H (m)	kg <sup>5)</sup>			
Pos. Item Rep Voce Pos. Ref. Поз.	Anz. Qty. Qte. Qta. Cant. Кол-во	<b>Drehbühne</b> / Slewing platform / Ensemble mât-cabine / Piattaforma girevole / Conjunto plataforma de giro / Plataforma giratória / Поворотная платформа			5,49	2,74	2,80	10120	
1	1								
2	1	<b>Turmspitze</b> / Tower head section / Porte-flèche section / Testa porta-braccio / Cabeza de torre / Cabeça de arpaio de lança / Оголовок башни			9,09	1,70	1,92	2800	
3	1	<b>Gegenausleger-Kopfstück</b> / Counter-jib head / Pointe de contre-flèche / Testa di controbraccio / Tramo punta de contrapluma / Cabeça de contra-lança / Концевая секция консоли противовеса			8,48	2,45	0,92	3050	
4	1	<b>Gegenausleger-Anlenkstück</b> / Counter-jib heel section / Pied de contre-flèche / Settore articolato di controbraccio / Tramo primero-contrapluma / Base articulada da contra-lança / Корневая секция консоли противовеса			8,44	1,77	0,92	2800	
5	1	<b>Gegenausleger-Zwischenstück</b> / Intermediate counter-jib section / Élément interm. de contre-flèche / Spezzone di controbraccio / Tramo intermedio de contrapluma / Peça suplementar da contra-lança / Промежуточная секция консоли противовеса			5,22	1,76	0,92	1550	
6	1	<b>Ausleger-Anlenkstück</b> / Jib heel section / Pied de flèche / Sezione articolata braccio / Pluma tramo primero / Base articulada de lança / Корневая секция стрелы			12,26	1,86	1,96	① 2980	
7	1	<b>Ausleger-Zwischenstück</b> / Intermediate jib section / Élément intermédiaire de flèche / Sezione intermedia braccio / Tramo intermedio pluma / Peça suplementar da lança / Промежуточная секция стрелы			10,26	1,63	1,87	②+③ 1880	
1	12,28				1,63	1,86	④ 2260		
1	5,32				1,63	1,86	⑤ 820		
1	10,27				1,63	1,86	⑥ 1220		
1	10,26				1,63	1,84	⑦ 800		
1	5,25	1,63	1,84	⑧ 510					
8	1	<b>Ausleger-Kopfstück</b> / Jib head section / Pointe de flèche / Punta braccio / Tramo punta de pluma / Cabeça de lança / Концевая секция стрелы			1,70	1,88	2,05	⑨ 280	
9	1	<b>Laufkatze und Lasthaken</b> / Trolley and hook / Chariot de distribution et crochet / Carrello con gancio / Carrito y gancho / Carro de ponte e gancho / Грузовая тележка и грузовой крюк			1,89	1,83	1,57	1150	
10	1	<b>Hubwerkseinheit</b> / Hoist gear unit / Treuil de levage / Gruppo meccanismo sollevamento / Mecanismo de elevación / Grupo de mecanismo elevatório / Блок грузовой лебедки			2,39	2,20	1,74	3300	
<b>Turm</b>		<b>Tower / Mât / Torre</b> Torre / Torre / Башня							
11	1	<b>Turmstück 2,9 m</b> / Tower section / Élément de mât / Elemento di torre / Tramo torre / Torre / Башенная секция			24 HC 420 TS-0290c	3,19	2,45	2,45	2950
12	9	<b>Turmstück</b> / Tower section / Élément de mât / Elemento di torre / Tramo torre / Torre / Башенная секция			21 HC 290 TS-0414c	4,14	2,30	2,30	2300
11	24 HC 420 TS-0580c				6,05	2,45	2,45	4500	
13	24 HC 630 TS-0580c				6,28	2,45	2,45	6480	
13	1	<b>Turmstück lang</b> / Long tower section / Élément de mât long / Elemento di torre, lungo / Tramo de torre largo / Peça de torre, comprida / Башенная секция, длинная			21 HC 290 TS-1242c	12,42	2,30	2,30	5770
					24 HC 420 TS-1160	11,80	2,45	2,45	7200
					24 HC 630 TS-1160	12,10	2,45	2,45	10750
14	1	<b>Grundturmstück</b> / Base tower section / Mât de base / Elemento di torre base / Tramo base / Peça de base de torre / Секция основания			21 HC 290 TSB-1242c	12,42	2,30	2,30	7940
<b>Klettereinrichtung</b>		<b>Climbing equipment / Equipement de télescopage / Attrezzatura per allungamento della gru</b> Equipo de trepado / Acessórios p. subida no edifício / Обойма наращивания							
15	1	<b>Führungsstück kpl.</b> / Guide section cpl. / Cage télescopique cpl. / Gabbia de sopraelevazione compl. / Torre de montaje completa / Peça de guia compl. / Направляющая секция в сб.			21 HC 290	8,39	2,68	2,58 (3,04)	5100
					24 HC 630	12,39	2,75	1,58	8300
16	1	<b>Hydraulikanlage, Stütz- und Klettertraverse</b> / Hydraulic unit, supporting and climbing cross members / Système hydraulique avec traverses d'appui et de télescopage / Sistema idraulico, traversa di appoggio e allungamento gru / Sistema hidráulico con traviesa de apoio y trepado / Instalação hidráulica, taversa de apoio e subida / Гидроагрегат, стойка-упор и траверса обоймы наращивания			21 HC 290	2,10	1,25	1,00	1150
					24 HC 630	2,10	1,10	1,00	1810

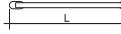
Pos. Anz.  
Item Qty.  
Rep. Qte.  
Voce Qta.  
Pos. Cant.  
Ref. Cant.  
Поз. Кол-во

L (m) B (m) H (m) kg<sup>5)</sup>

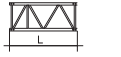
## Unterwagen Undercarriage / Châssis / Carro Carro con mástil / Carro de guindaste / Опорная рама

17	4	<b>Ausgleichsschwinge mit Schwingenlager</b> / Pivot for wheel box / Chape pour bogie / Bilanciere di equilibrio con cuscinetto bilanciere / Balancin / Balancim com suporte / Балансир с шарнирной опорой			24 HC 630	1,60	0,72	1,48	1390
18	2 4 4	<b>Fahrschemel mit Antrieb</b> / Rail bogie with drive Bogie moteur / Telaio con gruppo propulsore Caja rodillo motriz / Quadro sem grupo de propulsão Подрамник с приводом			21 HC 290 24 HC 630	1,63 (1,46) 1,45	0,92 (0,84) 0,76	0,95 (0,87) 0,72	1690 (920) 1200
19	2 4 4	<b>Fahrschemel ohne Antrieb</b> / Rail bogie without drive Bogie fou / Telaio senza gruppo propulsore / Caja rodillo conducido / Quadro com grupo de propulsão Подрамник без привода			21 HC 290 24 HC 630	1,37 (1,15) 1,30	0,62 (0,60) 0,40	0,95 (0,87) 0,72	1340 (880) 950
20	2 2 2	<b>Tragholm lang</b> / Long support arm / Longeron long Longherone lungo / Brazo soporte largo / Travessa comprida / Несущая балка, длинная			21 HC 290 24 HC 630	9,10 (11,95) 7,32 (5,91)	0,80 (0,82) 1,04 (0,92)	0,80 (0,80) 0,93 (0,93)	1650 (2200) 2330 (1980)
21	2	<b>Tragholm kurz</b> / Short support arm / Longeron court Longherone corto / Brazo soporte corto / Travessa curta / Несущая балка, короткая			21 HC 290 24 HC 630	4,45 (5,58) 7,14 (5,73)	0,77 (0,65) 1,04 (0,80)	0,77 (0,77) 0,90 (0,90)	800 (1035) 2135 (1780)
22	2 + 2	<b>Randträger</b> / Border support / Traverse Supporti base / Traviesa / Apoio de bordo Стяжная балка			21 HC 290 24 HC 630	5,46 – 5,40 (7,52 – 7,46) 9,30 (7,30)	0,11 – 0,18 (0,1 – 0,17) 0,24 (0,14)	0,16 – 0,38 (0,1 – 0,38) 0,41 (0,14)	175 – 525 (366 – 912) 870 (400)
23	4	<b>Stützholm</b> / Support strut / Hauban de châssis Correnti di appoggio / Tirante vertical / Travessa de apoio / Опорный подкос			21 HC 290 24 HC 630	4,14 (6,55) 6,98 (6,05)	0,18 (0,22) 0,26 (0,26)	0,25 (0,25) 0,39 (0,89)	320 (600) 1140 (1140)
24	1	<b>Unterwagen-Turmstück</b> / Undercarriage tower section / Mât de châssis / Elemento di torre del carro Tramo de carro / Peça de torre do chassis Опорная башенная секция			21 HC 290 24 HC 630	3,73 (6,70) 6,61	2,62 (2,53) 2,47	2,62 (2,53) 2,47	2550 (3800) 7930
25		<b>Kleinteile, Seile und Abspannungen</b> / Small parts, ropes and holding bars Accessoires, câbles et tirants / Accessori, funi e attrezzi di ancoraggio Despieces, cables y tirantes / Acessórios, cabos e peças de ancoragem Мелкие детали, Канаты и Пристежки			21 HC 290 24 HC 630	9,00	1,60	1,00	4000

( ) **Angaben in Klammern gelten für 8 m-Unterwagen.** / The data in brackets are valid for an undercarriage of 8 m. / Les données techniques indiquées entre parenthèses sont valables pour un châssis de 8 m. / Caratteristiche in (...) valgono per carro di 8 m. / Los datos entre paréntesis son válidos para carro de 8 m. / Características em (...) válidas pelo chassis de 8 m. / Данные в скобках относятся к 8-метровой опорной раме

<sup>5)</sup> **Einzelgewichte.** / Single weights. / Poids individuels. / Singoli pesi. / Pesos unitarios. / Pesos de peças componentes. / Индивидуальный вес.

**Konstruktionsänderungen vorbehalten!** / Subject to alterations! / Sous réserves de modifications! / Riservato il diritto di modifiche strutturali!  
¡Sujeto a modificaciones! / Salvo modificação da construção! / Права на внесение конструкторских изменений сохраняются!

**Sämtliche Angaben erfolgen ohne Gewähr.** / This information is supplied without liability. / Ces renseignements sont sans garantie. / Tutte le indicazioni fornite senza garanzia. / Declinamos toda responsabilidad derivada de la información proporcionada. / Declinamos qualquer responsabilidade quanto à informação fornecida. / Все данные указаны без обязательств.

**TCS-001599-LBC-01 • LN 303 - DIN 15018-H1/B3 • BGL C.0.10.0280 • 02.17 / 7**

Printed in Germany.